

AURORA FIRE PUMPS

DOUBLE WALL FUEL TANKS WITH FITTINGS

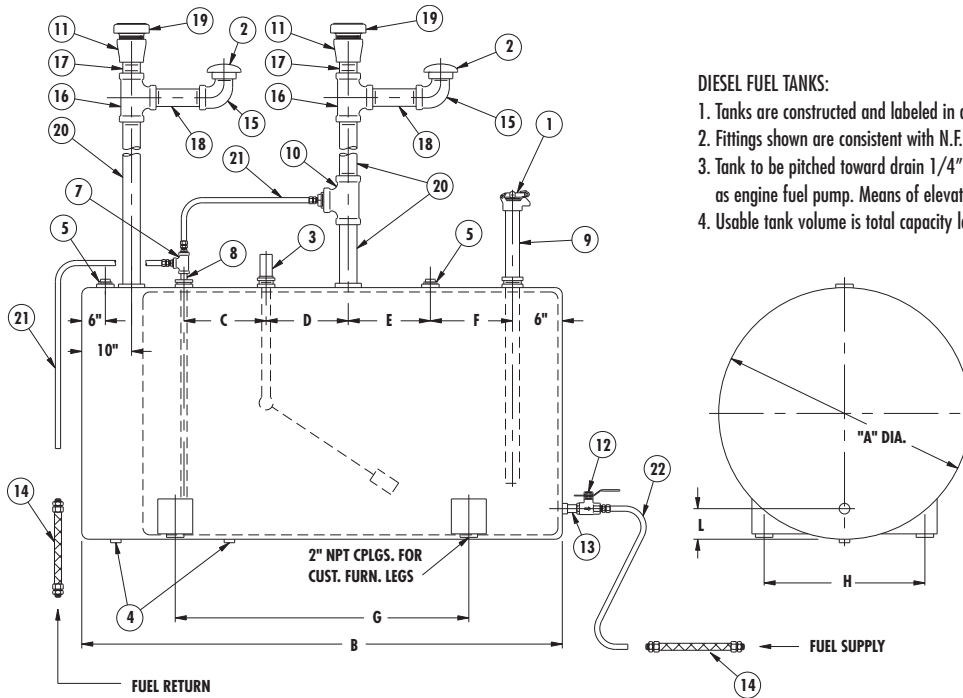

DIESEL FUEL TANKS:

1. Tanks are constructed and labeled in accordance with UL-142.
2. Fittings shown are consistent with N.F.P.A. 30 and UL-142..
3. Tank to be pitched toward drain 1/4" per foot with outlet on the same elevation as engine fuel pump. Means of elevating tank (by others) may be required.
4. Usable tank volume is total capacity less 5% for sump and 5% for expansion.

NOMINAL TANK SIZE IN GALLONS	USABLE VOLUME IN GALLONS	A	B	C	D	E	F	G	H	L	Z
119	105	24.5 (622)	73 (1853)	6 (152)	6 (152)	6 (152)	19 (482)	40 (1015)	14 (355)	3 (76)	4
187	165	31 (787)	73 (1853)	6 (152)	6 (152)	6 (152)	19 (482)	40 (1015)	16 (406)	3 (76)	4
300	270	39 (990)	73 (1853)	6 (152)	6 (152)	6 (152)	19 (482)	40 (1015)	22-7/8 (581)	3-3/4 (95)	4
359	320	41 (1041)	73 (1853)	6 (152)	6 (152)	6 (152)	31 (787)	40 (1015)	22-7/8 (581)	4 (102)	4
572	515	51 (1294)	73 (1853)	6 (152)	6 (152)	6 (152)	31 (787)	40 (1015)	30 (761)	5 (127)	4
849	766	65 (1651)	72 (1829)	6 (152)	6 (152)	6 (152)	19 (482)	44 (1118)	30 (761)	4-3/4 (121)	4
1100	993	65 (1651)	84 (2134)	6 (152)	6 (152)	6 (152)	37 (940)	44 (1118)	30 (761)	4-3/4 (121)	6

COMPONENTS FURNISHED BY OTHERS		
ITEM NO.	QTY. REQ'D	DESCRIPTION
20	2	"Z" Diameter Piping for Vent
21	1	1/2" Tubing and Fittings or 1/2" Black Pipe
22	1	3/4" Tubing and Fittings or 3/4" Black Pipe

COMPONENTS FURNISHED BY AURORA PUMP		
ITEM NO.	QTY. REQ'D	DESCRIPTION
1	1	2" NPT Lockable Fuel Cap
2	2	2" Screened Tank Vent
3	1	Fuel Gauge 1-1/2" NPT
4	2	1" NPT Drain Plug
5	2	2" NPT Pipe Plug
7	1	1/2" Tee
8	1	1/2" Close Nipple
9	1	2" Fuel Fill Pipe
10	1	"Z" x "Z" x 2" Tee
11	2	"Z" Coupling
12	1	3/4" NPT Lockable Fuel Valve
13	1	3/4" Close Nipple
14	2	Fuel Hoses for Supply & Return (Furnished by Engine Mfr.)
15	2	2" Street Elbow
16	2	"Z" x "Z" x 2" Tee
17	2	"Z" Close Nipple
18	2	"Z" x 6" Nipple
19	2	"Z" Emergency Vent

NOTES

1. All dimensions are in inches and may vary ± 1/4".
2. Components shown are shipped loose for field assembly.
3. Illustration is for component identification only. Actual installation must meet local codes and all applicable standards.
4. Item 10 may consist of a combination of fittings.
5. Refer to Section 916 page 259 for details of Aurora-furnished components.
6. Items 11 & 17 not required for 515 gallon tanks.

